

H. WYMAN.

Improvement in Shuttle-Box Operating Mechanisms.

No. 129,640.

Patented July 16, 1872.

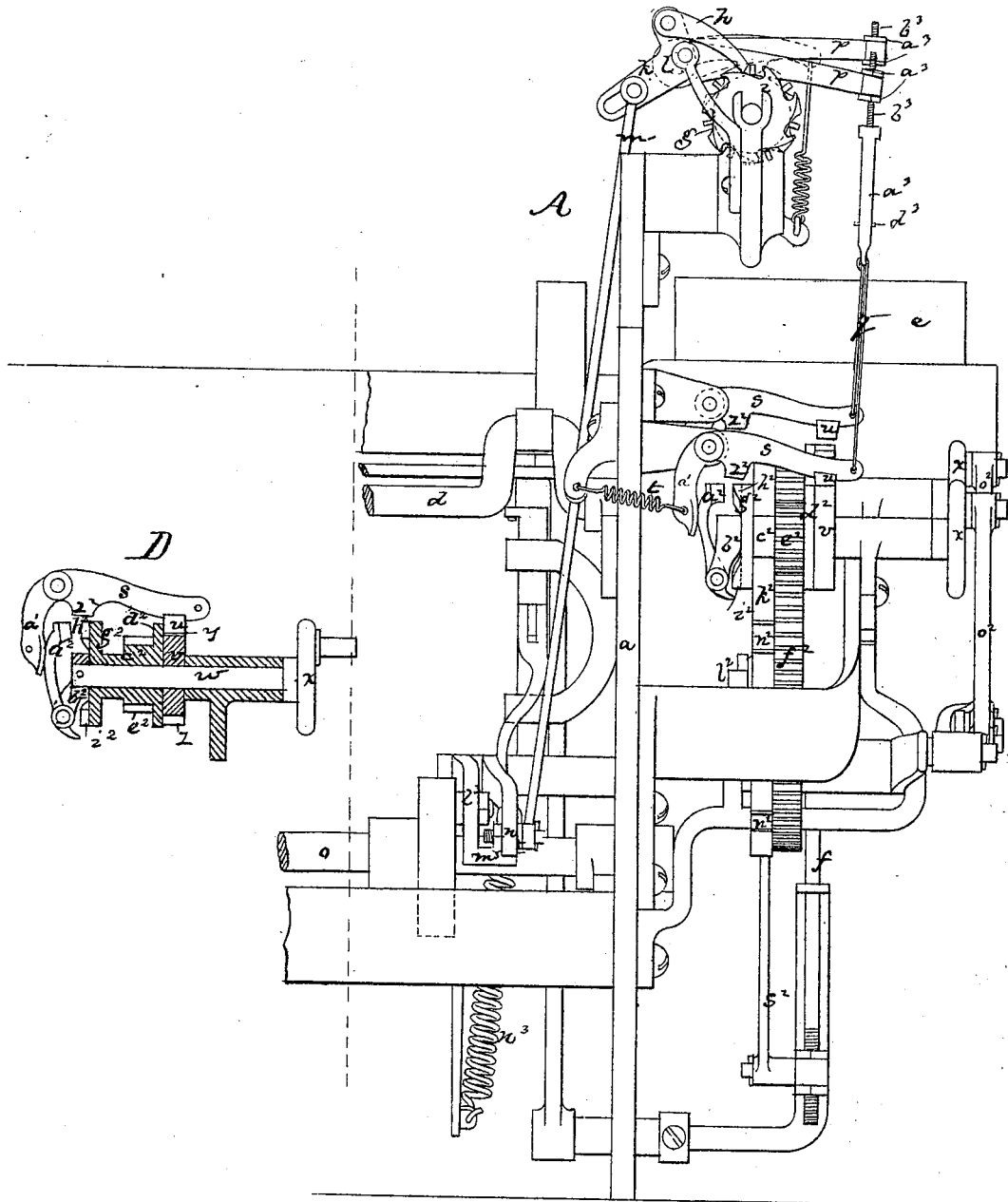

Witnesses,
Wm. W. Frothingham,
P. M. Hilder.

Inventor
Horace Wyman,
By his attys.
Crosby & Gould

H. WYMAN.

Improvement in Shuttle-Box Operating Mechanisms.

No. 129,640.

B

Patented July 16, 1872.

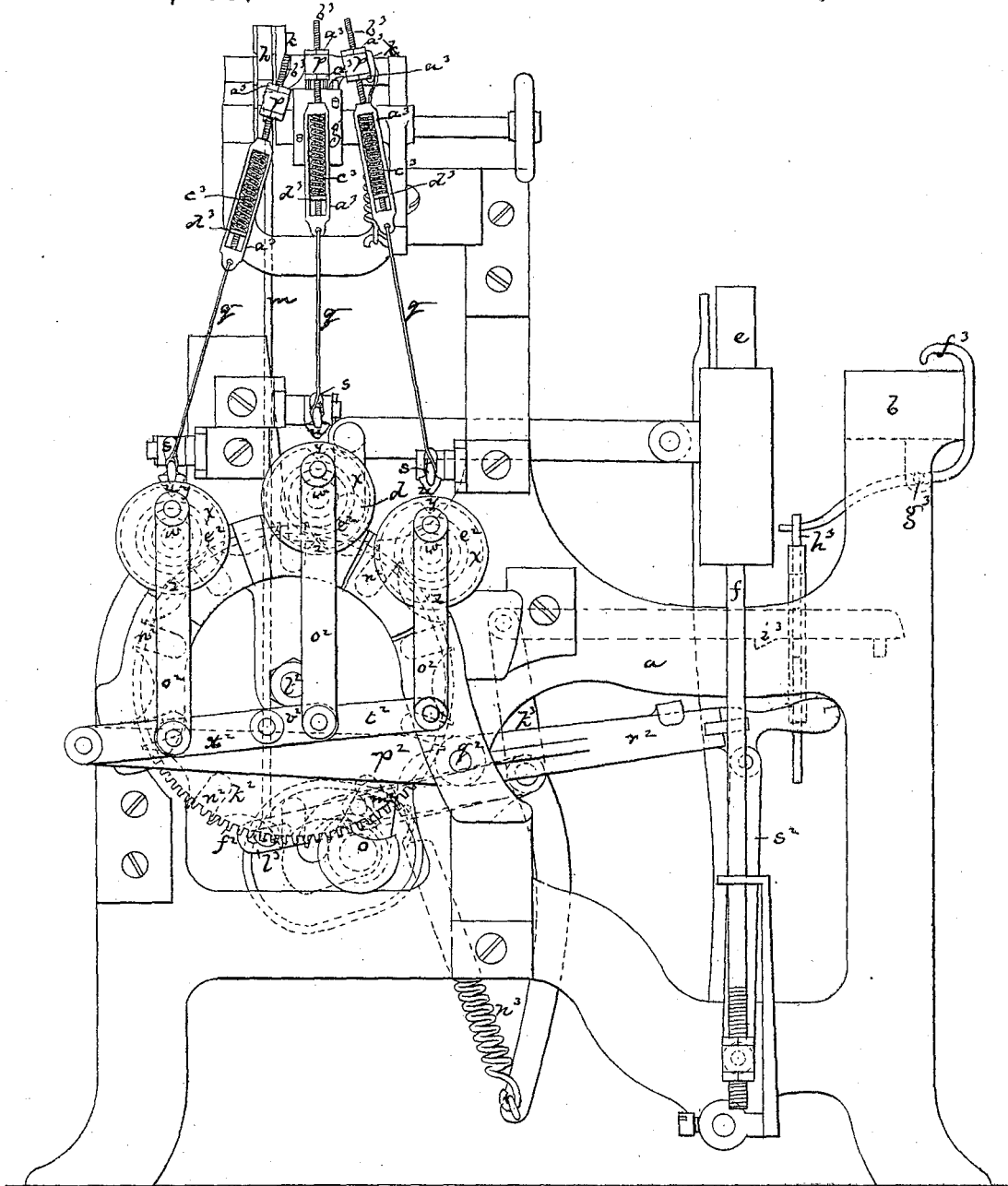

Witnesses.
M. W. Frothingham.
J. B. Kiddet.

Inventor
Horace Wyman.
By his Attys.
Crossley & Gould

H. WYMAN.

Improvement in Shuttle-Box Operating Mechanisms.

No. 129,640.

Patented July 16, 1872.

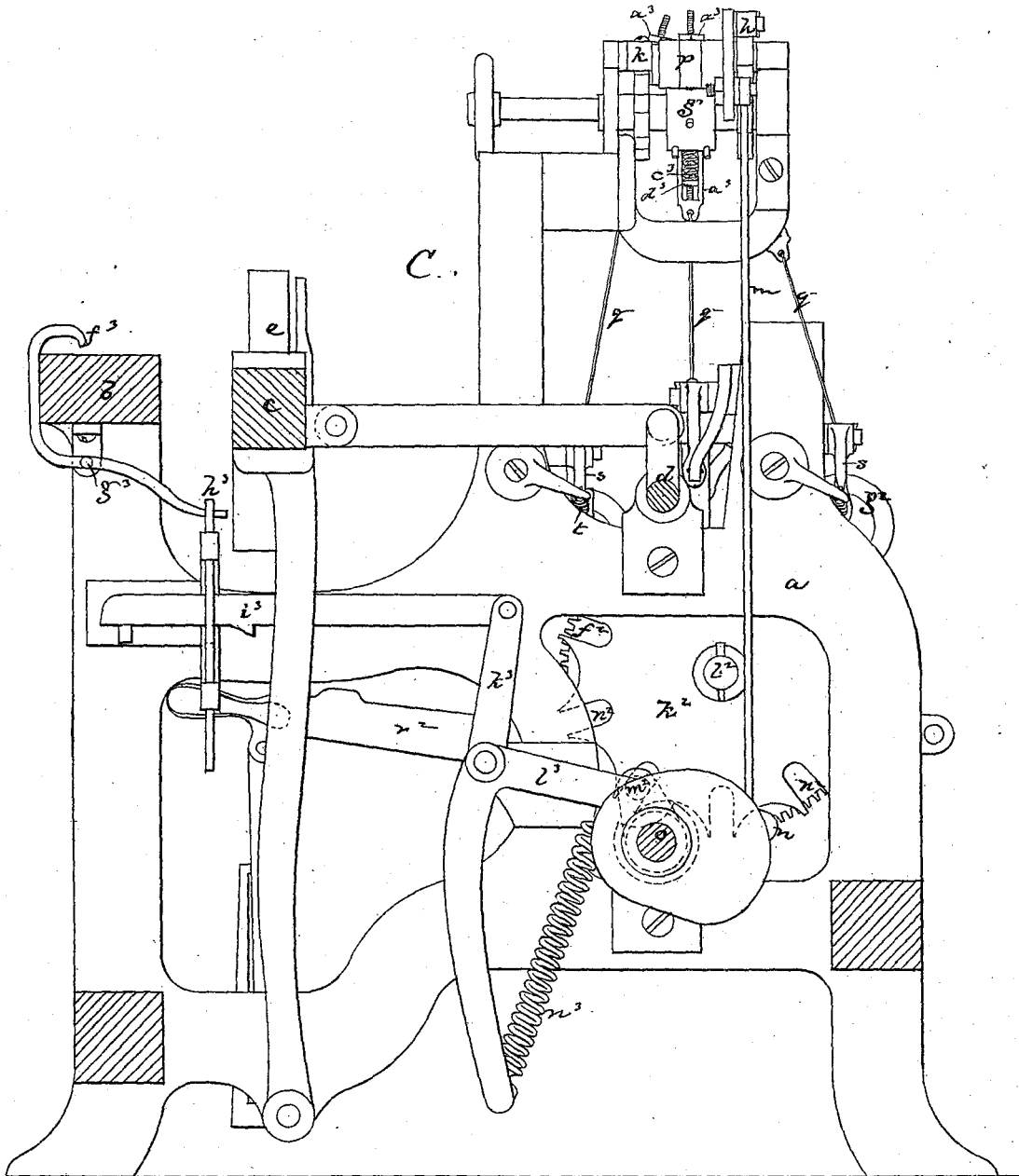

Witnesses:
 M. W. Frothingham.
 J. B. Kiddet.

Inventor
 Horace Wyman,
 By his Atty.
 Crosby & Gould

UNITED STATES PATENT OFFICE.

HORACE WYMAN, OF WORCESTER, MASSACHUSETTS.

IMPROVEMENT IN SHUTTLE-BOX-OPERATING MECHANISMS.

Specification forming part of Letters Patent No. 129,640, dated July 16, 1872.

To all whom it may concern:

Be it known that I, HORACE WYMAN, of Worcester, in the county of Worcester and State of Massachusetts, have invented certain Improvements in Looms; and I do hereby declare that the following, taken in connection with the drawing which accompanies and forms part of this specification, is a description of my invention sufficient to enable those skilled in the art to practice it.

United States Letters Patent Nos. 70,309 and 111,417 have been granted to me for improvements in looms. In said patent No. 70,309 I show an arrangement of compound levers, sliding racks, and gear mechanism, through which the drop-boxes are operated from the pattern-cylinder; and in said patent No. 111,417 I show a compound-lever drop-box mechanism, operated by an intermittently-rotated star and gear wheel which actuates a train of gear-pinion mechanism, connected with the pattern cylinder or chain, and with the compound-lever mechanism.

In my present invention I employ a compound lever in connection with a star-wheel intermittently operated from the cam-shaft, and having fixed to or connected with it a gear, into which meshes a series of pinions, each loose upon its shaft, and each having fixedly connected with it a notched wheel, which at times, and by the pattern chain or cylinder, is locked with a pawl that is connected with the shaft of said notched wheel, so that wheel and shaft turn together, each shaft having at its outer end a crank-wheel, connected by a link with some member of the compound lever, so that connection is made between the levers resting upon the pattern chain or cylinder and the box-levers by means of the crank-shafts and their links through the intervention of the loose pinions, operated from the star-wheel gear on the cam-shaft, the notched wheels fixedly connected to said pinions, and the pawls thrown into engagement with the notched wheels by levers actuated by the pattern chain or cylinder. It is in such a construction or organization that my invention primarily consists.

The drawing represents a lever or part of a lever embodying the invention.

A shows the mechanism in rear elevation. B is an end view; C, an elevation of the chain

or pattern mechanism, looking from the star-wheel side thereof. D is an axial section through one of the pinion-shafts.

a denotes the loom-frame; *b*, the breast-beam; *c*, the lathe; *d*, the crank-shaft that vibrates the lathe; *e*, one set of shuttle-boxes mounted on a slide-rod, *f*, which rod is connected to and operated by the chain or pattern mechanism, through the agency of the compound-lever mechanism and the mechanism connected therewith. *g* denotes the pattern-cylinder, intermittently rotated by a pawl, *h*, acting on a ratchet, *i*, at the end of the cylinder, the pawl being jointed to a rocker-lever, *k*, which is fulcrumed at *l*, and is connected by a rod, *m*, with a lever, *n*, intermittently raised by the action of a cam on a cam-shaft, *o*, the pawl moving the cylinder at each rotation of the cam-shaft. *p* are the arms or levers resting upon the pattern-chain or cylinder, and operated by the chain-rings or cylinder-pins to effect the successive and requisite movements of the boxes. The arms *p* are pivoted at *l*, and their front ends are connected by rods or wires *q* with the outer arms of levers *s*, the said lever-arms being drawn down by the stress of springs *t* acting upon the inner arms *a*¹ of the levers. Each outer lever-arm has a tooth, *u*, beneath which is a wheel, *v*, mounted on a shaft, *w*, at the outer end of which is a crank-wheel, *x*. Each wheel *v* has two diametrically-opposite peripheral notches, *y z*, and when the arm *p*, connected with either lever, rests directly upon the pattern-cylinder, the tooth enters one of the notches *y z*, and locks the wheel in position, or so that it cannot rotate, the wheel, when not so locked, being free to rotate. At the inner end of each shaft *w* is a locking-pawl, *a*², pivoted to an arm, *b*², fixed upon the shaft. Between each arm *b*² and the wheel *v* on the same shaft is a sleeve, *c*², rotating loosely on the shaft, and having a head, *d*², that rests against the wheel *v*, a pinion, *e*², that meshes into and is driven by the teeth of a gear, *f*², and at its inner end a lock-wheel, *g*², in the face of which are diametrically-opposite notches *h*² *i*², the pawl *a*² being thrown into engagement with one of said notches when its lever is actuated by the rise of the arm *p*, to which the lever is connected by the pattern-cylinder, the forward movement of the inner arm *a*¹ of the lever pressing the pawl forward and throwing it into

the notch of the wheel, and the same movement of the lever that thus engages the pawl and lock-wheel disengaging the lever-tooth u from the notch y of the wheel v . The pinion-driving gear f^2 forms part of or is fixed to a star-wheel, k^2 . The gear and star-wheel turn on a stud-pin, l^2 , being intermittently moved by a crank-pin, m^2 , on an arm extending from the end of the cam-shaft, the pin m^2 entering a notch, n^2 , of the star-wheel at each rotation of the cam-shaft, and thereby effecting the movement of the star-wheel. At each of such movements the gear-teeth turn all the pinions e^2 , imparting to each a half rotation, and if, by the action of the pattern-cylinder, any of the pawls a^2 lock into their lock-wheels g^2 , the shafts of said pawls will be correspondingly rotated a half rotation, while, if any of the pawls are out of engagement with their lock-wheels, by reason of the arms connected therewith resting upon the periphery of the pattern-cylinder, their pinions and lock-wheels will rotate without imparting movement to their shafts w and the wheels v fixed thereupon, each of such wheels v being detained by its lever-tooth u entering the peripheral notch y of the wheel. Thus, by the exigencies of the pattern, each crank-wheel x may be brought into two separate positions, and, by suitable connections with the box-supporting rod, corresponding changes of position may be effected in the boxes to bring either one of a series of boxes into line with the shuttle-race, the boxes being in number equal to the permutation changes which may be produced in the relative positions of the wheels. For communicating these changes we connect a crank-pin, o^2 , of each wheel by a link with one of the arms of the compound lever. The main arm p^2 of this lever is fulcrumed on a rotating pivot, q^2 , an extension, r^2 , of the lever being connected by a link, s^2 , with the drop-box rod. To the arm p^2 is jointed one end of an arm, t^2 , whose other end is connected by a link, o^2 , with the crank-pin of one of the wheels x . To the arm t^2 is pivoted another lever, (or member of the compound lever,) one arm v^2 of said lever being connected by a link, o^2 , with another of the wheels, and the other arm x^2 by a link, o^2 , with the third wheel x of the series, the lever-arm r^2 being brought into position to bring either one of six boxes into line with the race, accordingly as, by the instrumentality of the pattern cylinder or chain and the connections therewith of the compound-lever arms, said arms are positioned. Each rod or wire q is connected with its chain-cylinder arm p by means of a stirrup, a^3 , to the bottom of which the wire or rod is fastened, while a screw rod or bolt, b^3 , passes through the top of the stirrup and through a coiled spring, c^3 , the bottom of which spring bears against a nut, d^2 , on

the rod, while the top bears against the under side of the upper stirrup-bar, the upper screw-threaded end of the rod being fastened to the arm by nuts e^3 . By turning these nuts the strain upon the rods may be adjusted, and the length of the rods so maintained as to insure the proper relations between the levers s , wheel-notches y z , pawls a^2 , and lock-wheel notches h^2 i^2 .

When the free end of either pawl a^2 is up and the lever s is not raised by the pattern-cylinder, the weight of the pawl will keep it out of its notch; but when the pivoted end is up, and the lever not raised, the pawl will be kept from the notch by the action of a projection, z^2 , of the lever.

By breakage of a thread the thread motion knocks off the loom by striking an arm, f^3 , turning a shaft, g^3 , which lifts a slide, h^3 , causing a latch, i^3 , to catch upon said slide, this latch being connected to an arm, k^3 , extending from the lever that actuates the pattern-cylinder, arresting the cylinder, and keeping the boxes from being operated. To prevent breakage of any of the mechanism by sudden stop of the cam-shaft, I cause the cam to act indirectly on the lever k^3 by employing an auxiliary lever, l^3 , having the pin or roll extending into the cam-groove, the upper arm of the lever having a projection, m^3 , that extends under the lever n , and the lever n being held normally in position (or so that in effect there is but one lever) by the stress of a spring, n^3 , which spring will permit one or two rotative movements of the shaft o after the lever n has been arrested, so that the loom is stopped without breakage from too sudden stoppage.

I claim—

1. The combination of the compound-lever mechanism with the pattern chain or cylinder through the intervention of rotary pinions operated by an intermittently-rotating gear and mechanism, as described, operated by the pinions in accordance with the exigencies of the pattern.

2. In combination with the described compound-lever mechanism for directly actuating the drop-boxes, the crank-wheels, pinions e^2 , notched wheels g^2 , and lever and pawl mechanism, the crank-wheels being connected with the compound-lever mechanism, the wheel, lever, and pawl mechanism with the pattern chain or cylinder, and the pinions with the intermittently-operated gear, all substantially as shown and described.

3. The levers l^3 k^3 , spring n^3 , slide h^3 , and latch i^3 , in combination with the stop mechanism, substantially as shown and described.

HORACE WYMAN.

Witnesses:

J. A. WARE,
FRANCIS GOULD.